

Rückseite des Steckers
mit Terostat-92 abdichten
Plugging the rear side of
the connector with Terostat-92



28980068



2

Schirmring wird nicht benötigt (Lieferumfang 19730621)
Shielding ring is not required (supplied 19730621)

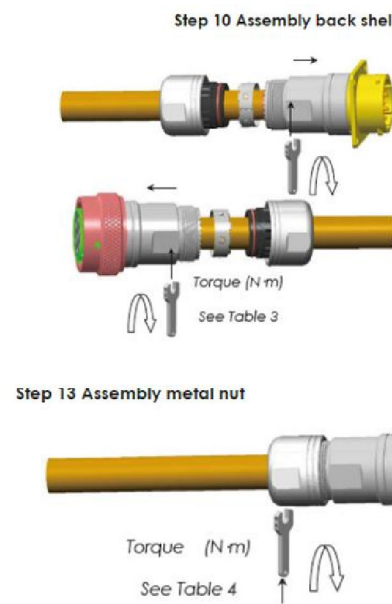

Table 3		Table 4	
Size	Torque=T1 (N.m)	Size	Torque=T2 (N.m)
10	1.5-2.5 N.m	10	2.0-3.0 N.m
12	2.5-4.0 N.m	12	3.0-5.0 N.m
14	2.5-4.0 N.m	14	3.5-5.5 N.m
16	3.0-4.5 N.m	16	4.0-6.0 N.m
18	3.0-4.5 N.m	18	5.0-8.0 N.m



Schrumpfschlauch als Markierung über das Ende
des Wellenschlauches schrumpfen (bündig abschliessend)

Shrink heat tube for marking
over the end of the corrugated tube (to be flush with)

Kette der Schutzkappe mit Schlüsselring verbinden
Connect chain of the protection cap with key ring

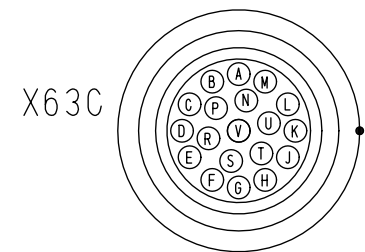

- 19730639
- 19730621
- 19730613

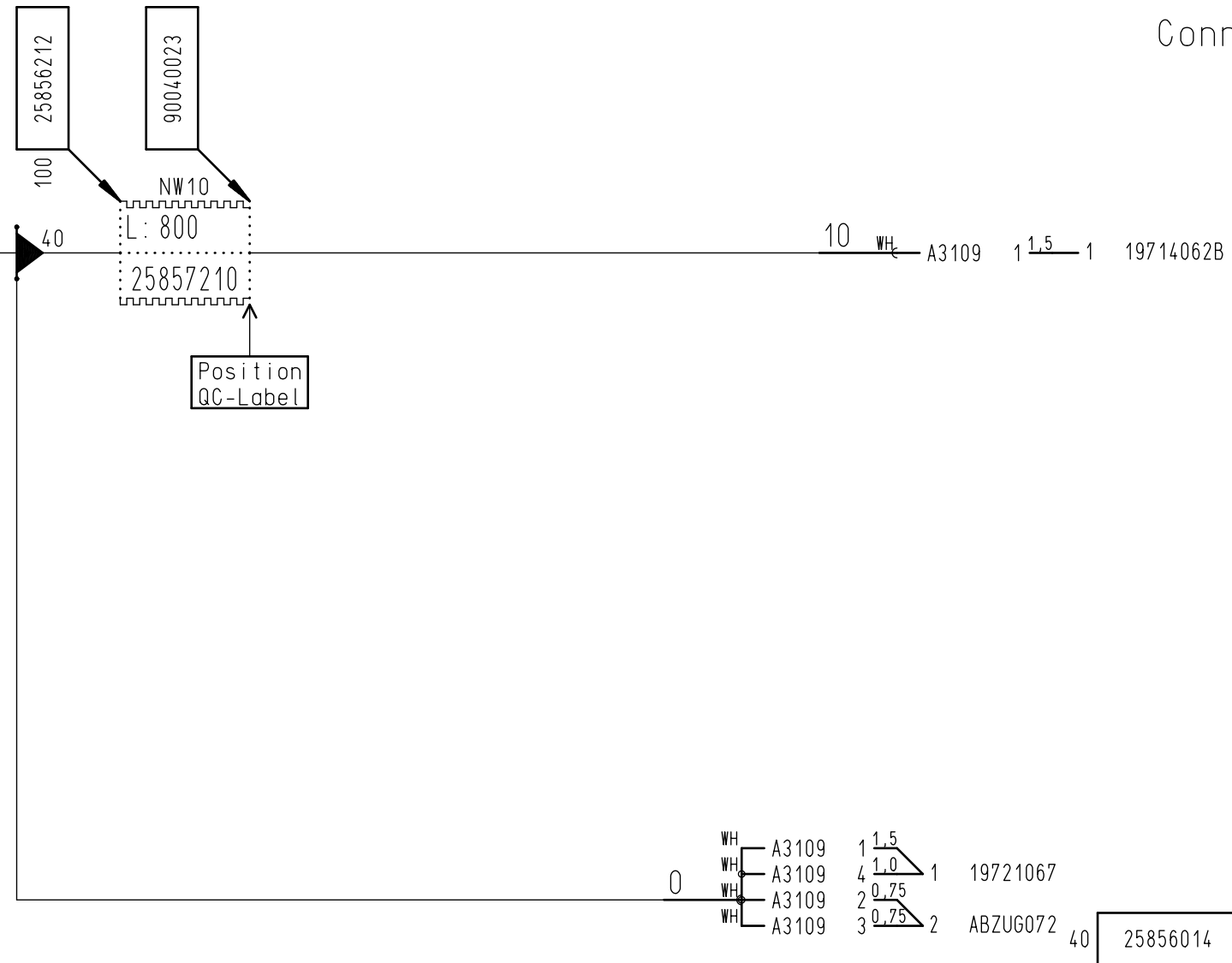
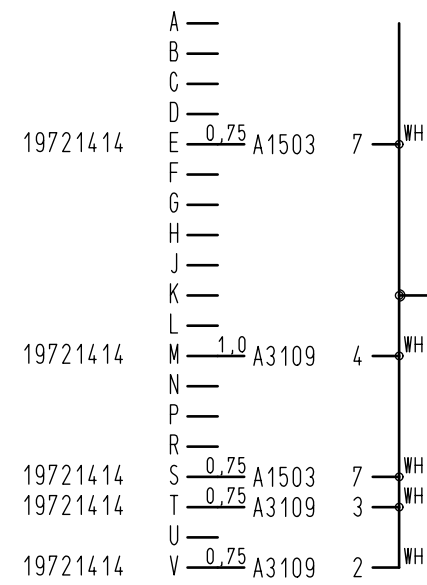

Toleranzen / tolerances	
0 - 100 mm	- 0/+10 mm
101 - 500 mm	-10/+10 mm
501 - 2000 mm	-10/+20 mm
> 2000 mm	-10/+30 mm

The tolerances are made for individual measurements and for the sum of several measurement

All housings with internal length

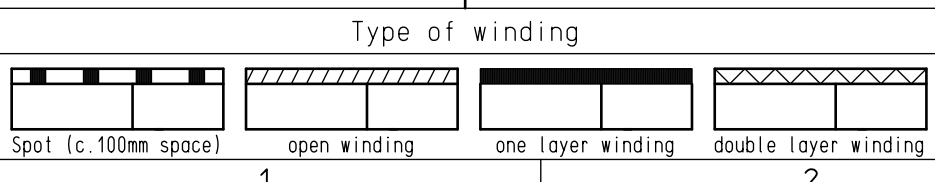

2		1x		3327-00		18.07.16		DK		2015		Date		Name		Citymaster 1600		Name		Kabelbaum W23 (Univ._Mähwerk)		Drawing Number		97134134			
A2		No. Number appears		Change No.		Date		Name		Standard		Change No.		3001-67		For this drawing we reserve all rights (acc. DIN ISO 16016)		KABI 472		Type 1491		Dep. ELK		No. of Sh. 2		Sheet 1	

All parts have to be in conformity to IEC 60335-1/-2-72
All housings have to be labeled with device tags

W23

cutting list-No. : 97134134		cutting list Kabelbaum W23 (Univ._Mähwerk)									
-----------------------------	--	--	--	--	--	--	--	--	--	--	--

wire	Sub	part-No. contact 1	part-No.comp.part	marking 1	wire	cr. sec.	length	colour	marking 2	part-No. contact 2	part-No.comp.part
A1503	7	19721414		X63C/E	26210310	0,75	80	WH	X63C/S	19721414	
A3109	1	19714062B	25856295-L15	X49/1	26210252	1,5	770	WH	XS56/1	19721067	
A3109	4	19721414		X63C/M	26210245	1,0	120	WH	XS56/1	^	
A3109	2	19721414		X63C/V	26210310	0,75	70	WH	XS56/2	ABZUG072	
A3109	3	19721414		X63C/T	26210310	0,75	70	WH	XS56/2	^	

2	.	3327-00	18.07.16	DK	2016	date	name	Citymaster 1600	 Hako GmbH D-23840 Bad Oldesloe	Kabelbaum W23 (Univ._Mähwerk)		
					drawn	27.04.	DK	replaced by : same no.				
					check			rev. No. : 3001-67		type : 1491	97134134	num.ofsh.:2 sheets: 2
No.	changed wire/Sub-No.	Rev.-No.	date	name								

Material: 97134134 wiring harness
 Index: 02
 Change Number: 3327-00

Material	Item	Line	Component	Object description	Material Description	Comp. Qty (CUn)	Un	Internal Comment
97134134	10	1	19714062	Ringkabelschuh ähn. DIN 46225 A6-2,5	ring term. similar DIN 46225 A6-2,5		1 PC	
97134134	10	2						Fa. Lear Nr. 25219.123.322
97134134	20	1	19721067	Stossverbinder >1-2,5 unisoliert	butt connector >1-2,5 not insulated		1 PC	
97134134	20	2						Fa. Lear Nr. 04529.321.011
97134134	30	1	19721414	ST-Kont. RT 1,6mm (0,75-1,5)	tab-cont. RT 1,6mm (0,75-1,5)		5 PC	
97134134	30	2						Fa.Amphenol Nr. SP16M1G10
97134134	40	1	19730613	Stecker für Stiftkontakt 19pol.	socket for pin contact 19-pole		1 PC	
97134134	40	2						Fa. Amphenol Nr. RT061619PNH-Ni
97134134	50	1	19730621	Endgehäuse m.Kabelverschraubung	cord grip, shell size 16		1 PC	
97134134	50	2						Fa.Amphenol Nr. RT0L-16CG-S1-Ni
97134134	60	1	19730639	Staubschutzkappe Stecker	plug dust cap		1 PC	
97134134	60	2						Fa.Amphenol Nr.RT616DCG-15-Ni
97134134	70	1	25856014	Schrumpfsch. 4,5x1-PE 3:1 trans.m.Kleber	heat shrink tube 4,5x1-PE 3:1 tran.glu		0,04 M	
97134134	70	2						Fa. Thulesius Nr. Z85527
97134134	70	3						Meterware
97134134	80	1	25856212	Schrumpfschlauch 12,7x0,6-PVC 2:1 rt	heat shrink tube 12,7x0,6-PVC 2:1 red		0,1 M	
97134134	80	2						Fa. Thulesius Nr. Z85892
97134134	90	1	25856295	Schrumpfschlauch 4,8x0,5-PVC 2:1 bl	heat shrink tube 4,8x0,5-PVC 2:1 blue		0,02 M	
97134134	90	2						Fa. Thulesius Nr. Z85877
97134134	100	1	25857210	Wellschlauch geschlossen NW10 flexibel	corrugated tube NW10		0,8 M	
97134134	100	2						LV: Stöhrmann GmbH <(>&<)> Co. KG 50 Meter/Lieferantengebinde (GB 20)
97134134	100	3						-
97134134	100	4						Kanban-Teil Artikelkurzauftrag vorh.
97134134	100	5						
97134134	100	6						
97134134	100	7						Fa.Reiku Nr.PARRB-10F
97134134	110	1	26210245	PVC-Fahrzeugleitung FLRY-B 1x1 weiss	PVC-automotive cable FLRY-B 1x1 white		0,12 M	
97134134	110	2						Fa. NKT Art.: AP040010BNNNNAN
97134134	110	3						
97134134	110	4						DIN 72551 / ISO6722 FLRY-B
97134134	130	1	26210310	PVC-Fahrzeugleitung FLRY-B 1x0,75 weiss	PVC-automotive cable FLRY-B 1x0,75 white		0,22 M	
97134134	130	2						Fa. NKT Art.: AP040007BNNNNAN
97134134	130	3						
97134134	130	4						DIN 72551 / ISO6722 FLRY-B
97134134	140	1	28980068	Terostat 92 schwarz	sealing compound		0,1 PCD	
97134134	140	2						Fa. Henkel 310MI
97134134	140	3						Zu verarbeiten mit Reiniger 28420594
97134134	150	1	90040023	Schlüsselring 26,5x22x1,9	key ring		1 PC	
97134134	160	1	26210252	PVC-Fahrzeugleitung FLRY-B 1x1,5 weiss	PVC-automotive cable FLRY-B 1x1,5 white		0,77 M	
97134134	160	2						Fa. NKT Art.: AP040015BNNNNAN
97134134	160	3						
97134134	160	4						DIN 72551 / ISO6722 FLRY-B